

E

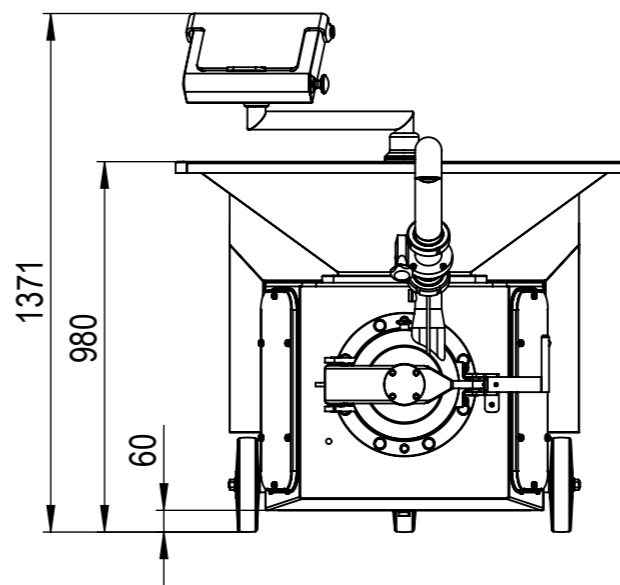

Ausleitrohr vorne
outfall pipe forward

2311

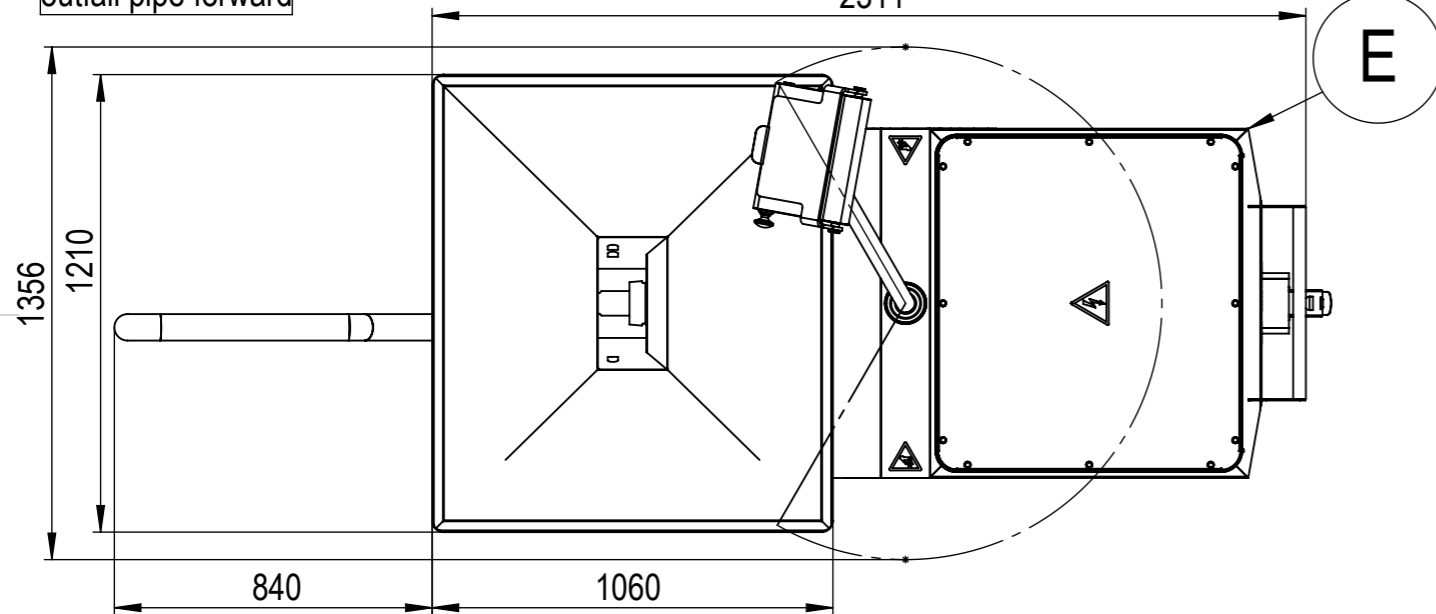

E

Ausleitrohr Kutter
outfall pipe cutter

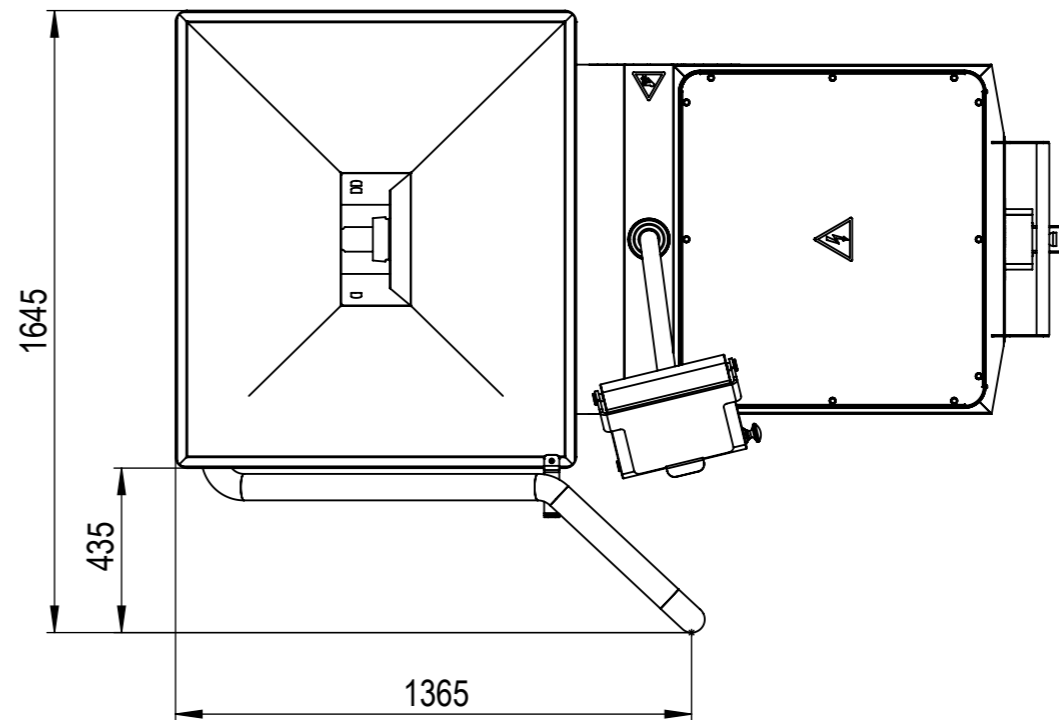

Ausleitrohr seitlich
outfall pipe sideways

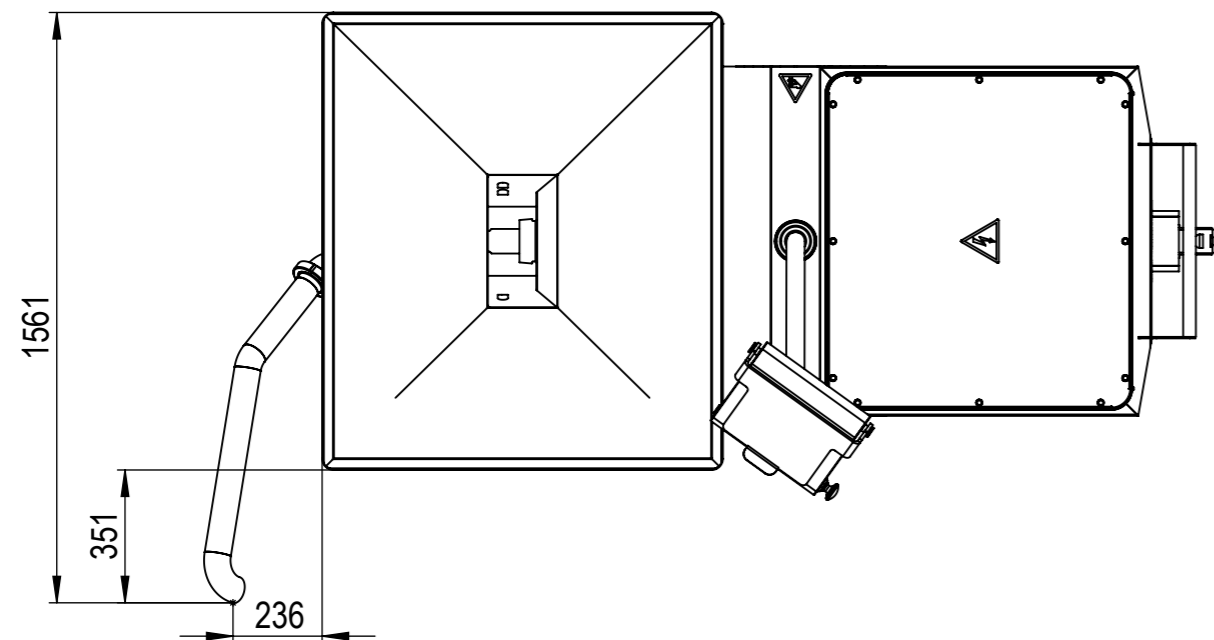

Konfiguration Maschine / Configuration machine

Automatische Regelung der Auslauftemperatur / Automatic regulation of discharge temperature	Nein / No
Magnet zur Metallabscheidung / Magnet for metal separation	Nein / No
Reinigungswagen / Cleaning trolley	Nein / No

customer / country: - /

DIMENSION SHEET

name: Feinstzerkleinerer / Emulsifier

type: FZ225-H

Maschinenfabrik LASKA Gesellschaft m.b.H.
Makartstraße 60, 4050 Traun - Austria
T +43 7229 / 606-0
laska@laska.at

© Maschinenfabrik LASKA
Gesellschaft m.b.H. 2020
Schutzvermerk ISO 16016 beachten

machine number:	-	model:	FZ0225-H / 120121	drawn:	Admin
first-angle projection		all dimensions in mm	do not scale this dwg	sheet:	1 / 1
scale:	1:20	drawing number:	FZ0227-H_01000	LASKA	